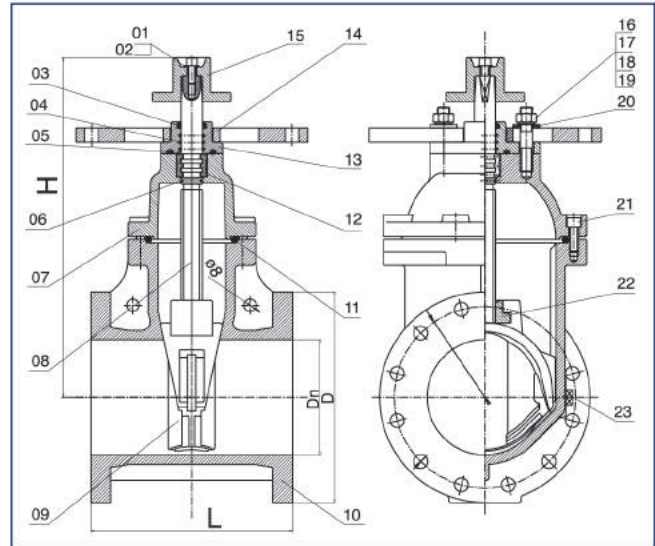

**300PSI-NRS Type Flanged End Gate Valve,UL/ULC Listed,FM Approved****Model No.:Z45-300****Technical Specifications:**

- 1.Design Standard:AWWA C515
- 2.Nominal Pressure:300PSI
- 3.Flange standard :ASME/ANSI B16.1 Class 125 or ASME/ANSI B16.42 Class 150 or BS EN1092-2 PN16 or GB/T9113.1
- 4.Epoxy resin coating both inside & outside the body
- 5.It could also be operated by the handwheel

**SIZE CHART**

SIZE ITEM	2-1/2"	3"	4"	5"	6"	8"	10"	12"
Dn	65	80	103	128.5	155	204	255	304
L	190	203	229	254	267	292	330	356
D	178	191	229	254	279	343	406	483
H	292	322	342	412	448	534	635	720

23	Plug	2	C95400
22	Masterscrew	1	C95400
21	Inner Hexagon Screw	n	Steel
20	Washer	n	Steel
19	Washer	n	Steel
18	Spring Washer	n	Steel
17	Studs	n	S.S.304
16	Nut	n	S.S.304
15	Link Block	1	DI
14	Terminal Pad	1	DI
13	Gland	1	DI
12	Retaining Ring	2	C95400
11	Sealing Ring	1	EPDM
10	Body	1	DI
09	Disc	1	DI+EPDM
08	Stem	1	S.S.304
07	Bonnet	1	DI
06	O-Ring	1	EPDM
05	Sealing Ring	1	EPDM
04	O-Ring	3	EPDM
03	Sealing Gland	1	EPDM
02	Inner Hexagon Screw	1	S.S.304
01	Flat Washer	1	S.S.304
<b>NO.</b>	<b>Name</b>	<b>Qty.</b>	<b>Material</b>